

Guani kitaabee

impayi

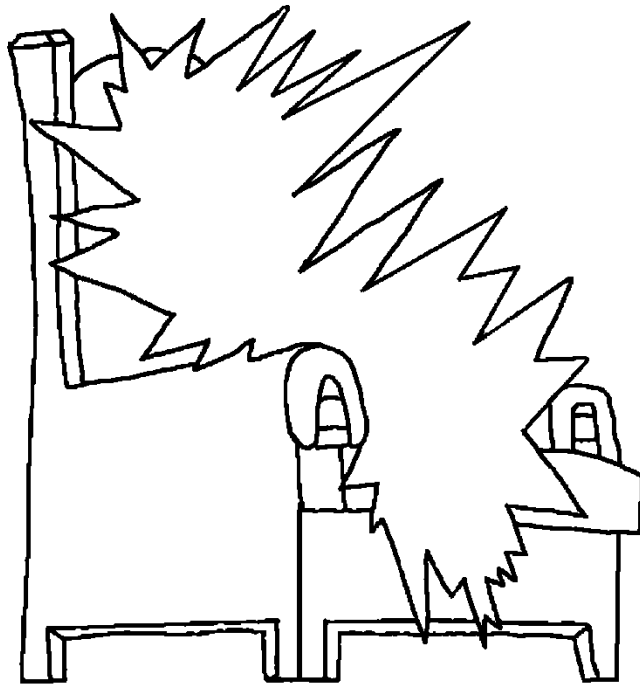

Ardiana,
Ala ka
frampré



Safandee: Edward Hughes

Ayandi: Lazarus
Alastair Paterson

Adadomou: Sarah S.

Agua mokho nkonga: christian-translation.com

Ayee kouni: Bible for Children
www.M1914.org

©2021 Bible for Children, Inc.

License: Iri ki nanga nanti guani mpi fay kha makha guagua.



Isa guini biréné gnigné ké nkhamana agni ardiana
khibaaro nkongo I almoudo ni ndanga. Agna xilli
"Mpa ba nka", arko ngi danga nanti
doono ka nguébé nguéyi.

Ardiana ayam frampro
nta sou ayankhoronta
sou aro douna
nti sikki.

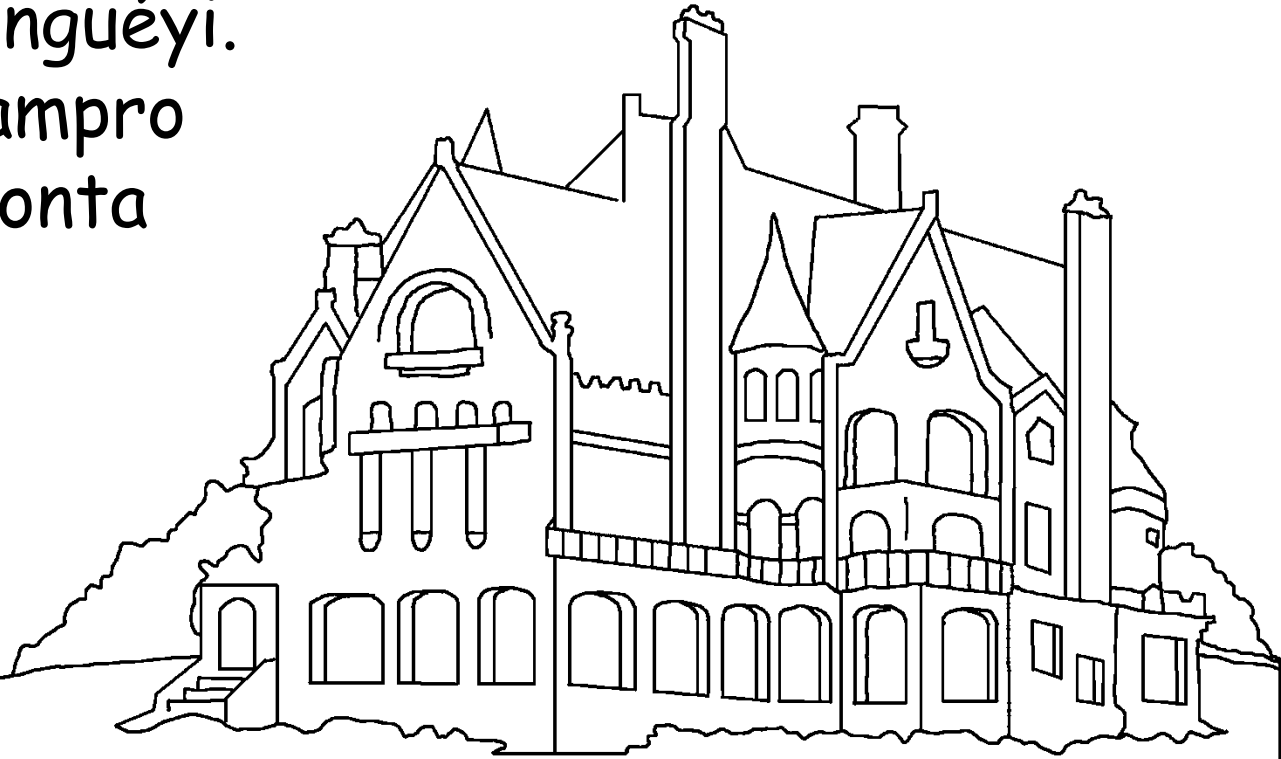

Isa séffi danga, "Batté lé nokhou débeury khada nga. Khari nguana dagua nga dinguirá débeury kha danga, nguérini guéma kha ya". Isa dgua aridiana, kempalé ague guidi khin kho nga. Almoudo kougui gna fayni, Isa idi séguéndi, kempalé tobolou iri mokhondi.

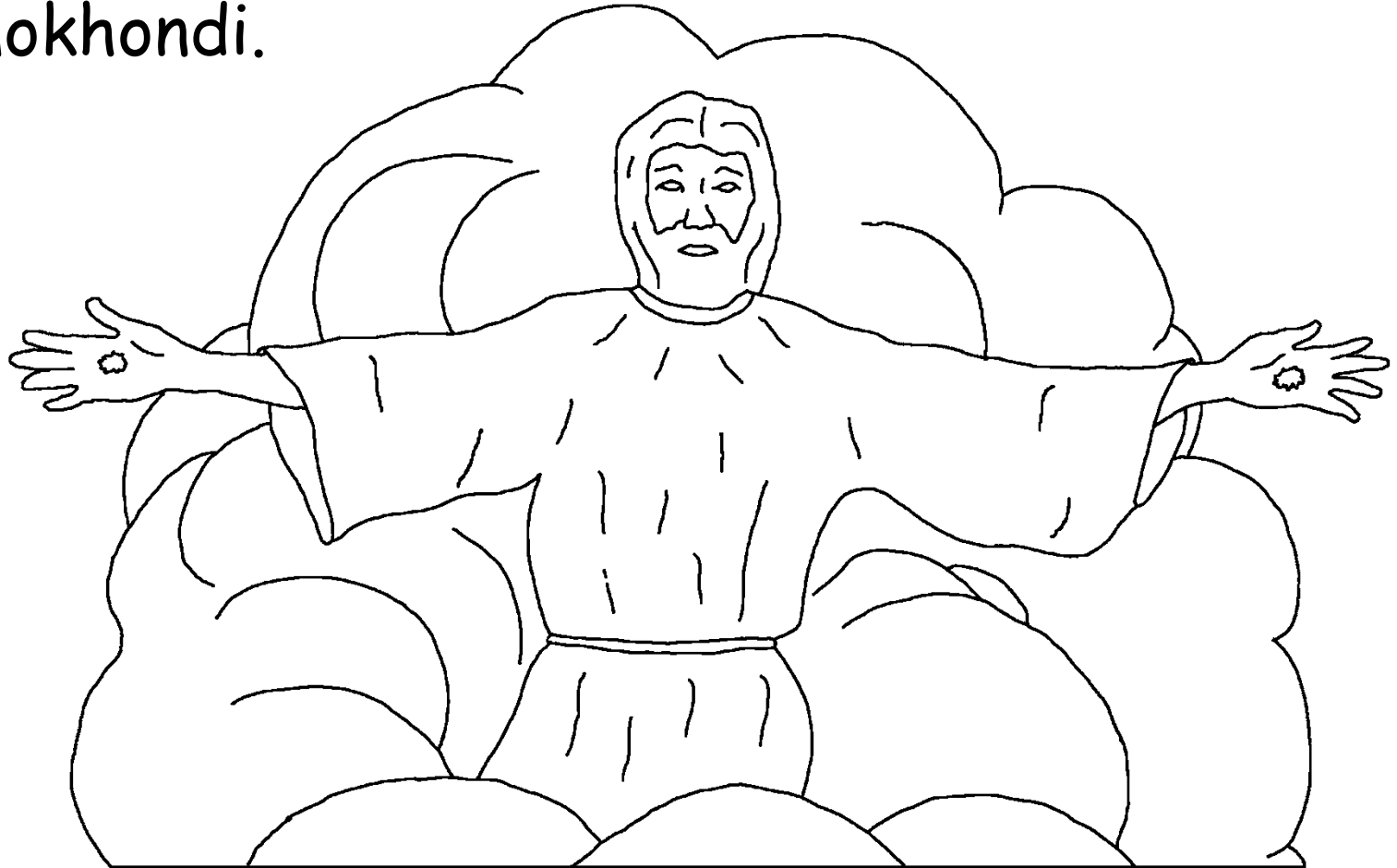

Guiliké ndima, alakhorou isiméné Isa guiri laydou
béréguida ti irini iwoutou. Isa ti iguana irini ini
djouwana, iguima djigui nokhobé. Wathia
kaffri koubé niki kara kempalé?
Kiitabe ké ti ikounté léya Isa
nokho nga. A nganta
ampété nokho nga,
ando Ala y doomé.

Naa dou ko
ado Ala

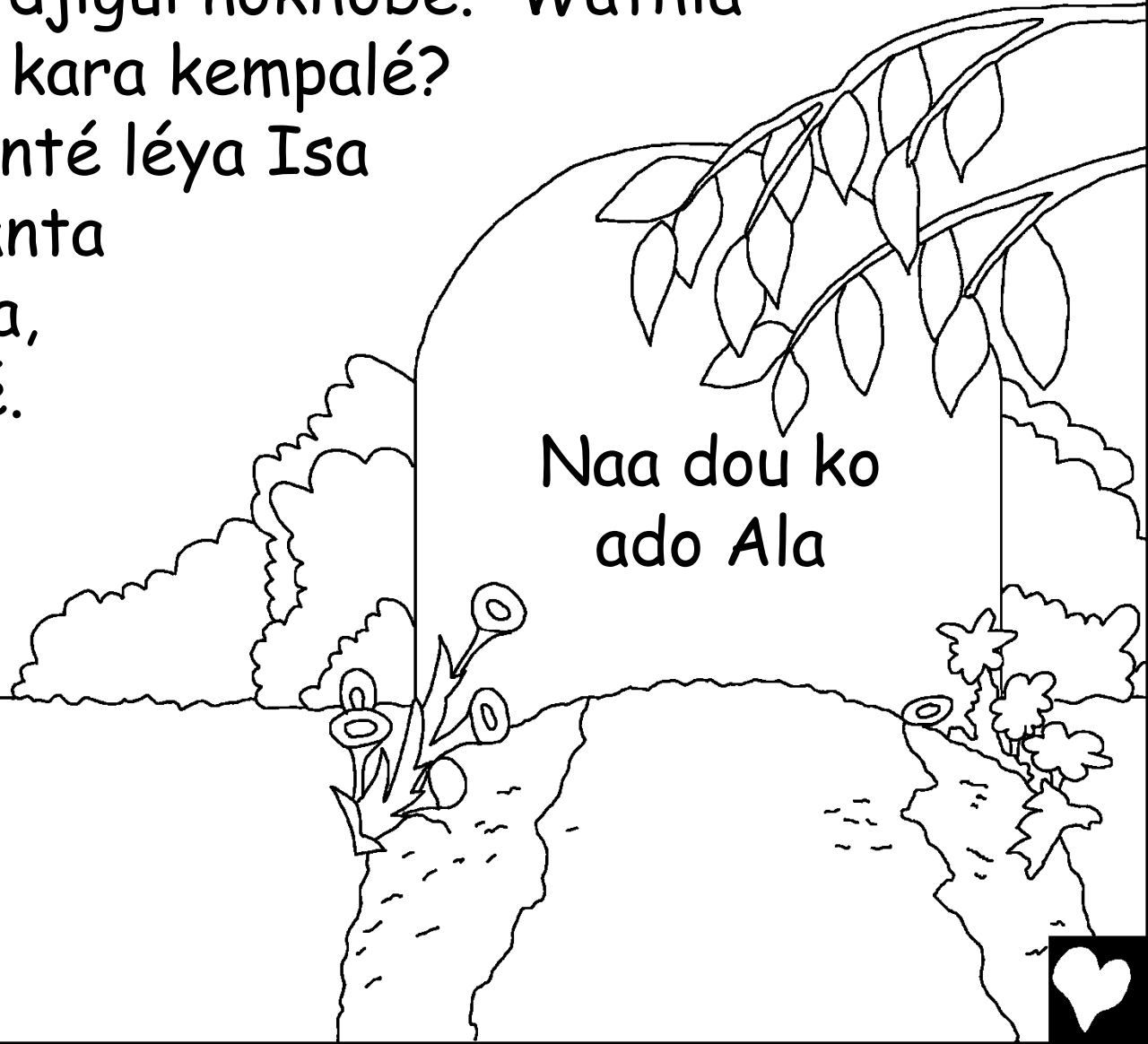

Révélation, buki léguiri nté kitaabé, ayani kongo
danga ardiana frampré gnani. Kébé gua lingue nka
sou ké ni, ardiana ayani Ala ka. Ala ayi nokhou
ntiou, agua takhounou kébé
nkhama ani ardiana.

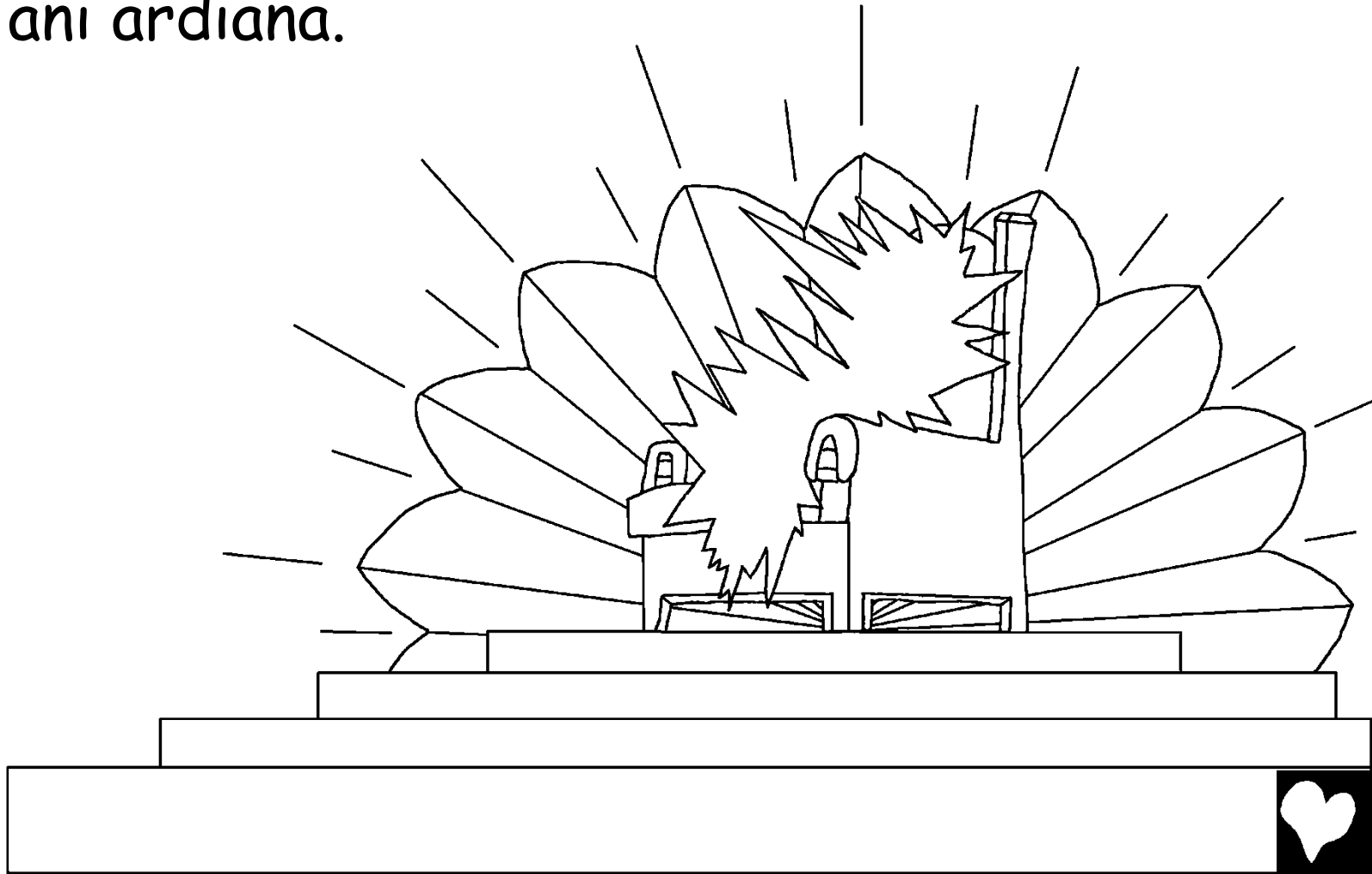

Malakay noukou aro soro tanani idioppé Ala batta.
Nka kho adama rémé koubéni sougou kara isotagua
ardiana. Isougounou sougou
lingue igua Ala tigua.

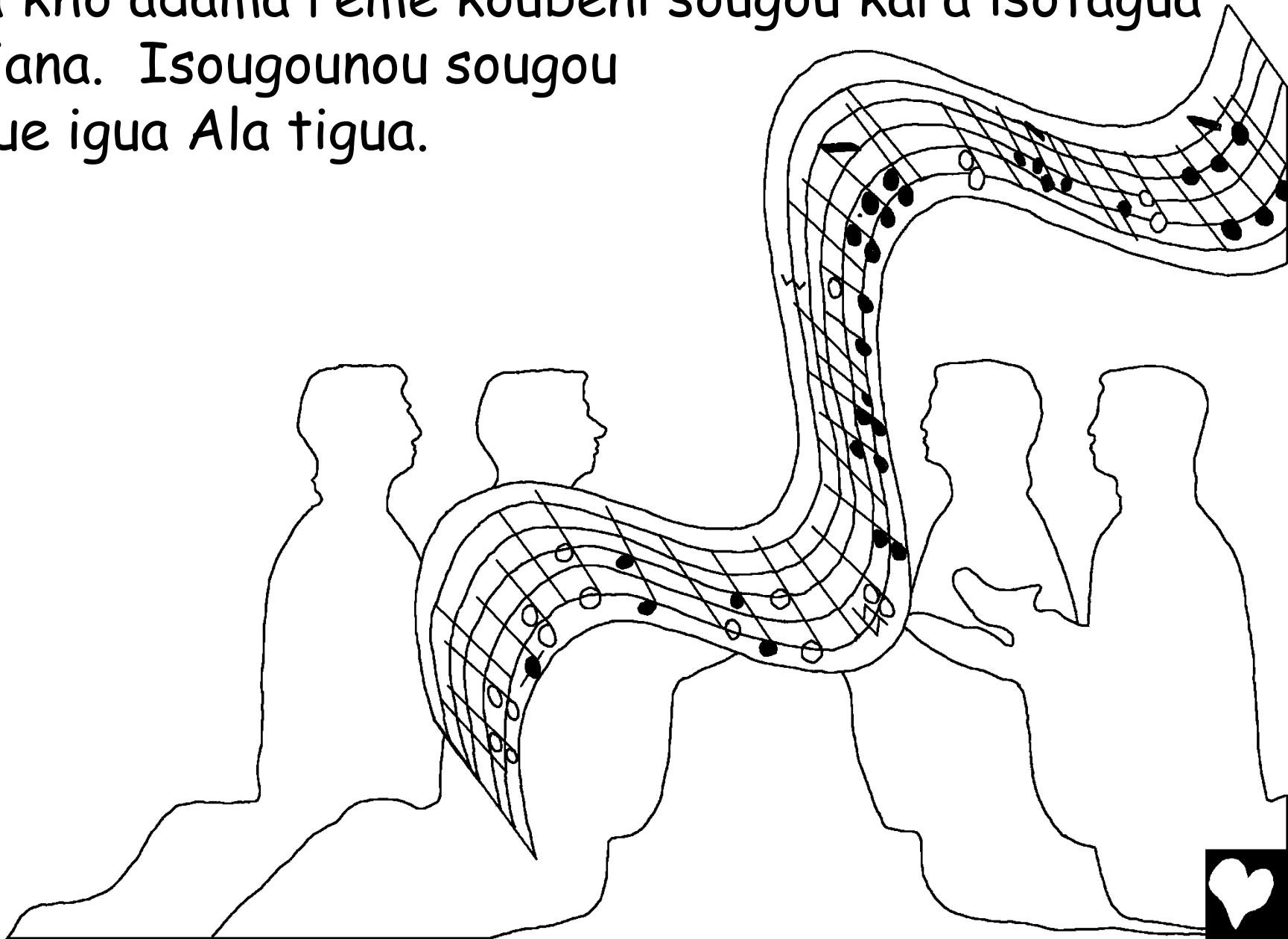

Dingua nkhanou yaani igua sougué ké sougounou:
A DIARÉ ODANGUA AGNANDO ALA TOUGUO
DANGA ADO AMPERE ANDO
GNA KHIRSOU ARO
MOODINI TI ALA
NOKHO MA. (Rev. 5:9)



Dingua nkhanou légeury kébé nga kitaabe ké nokho y
ardiana mokho kongo da "Jérusalem fo kouroumba".
A dinka dinka, ado téguéyé guile agua sella.
Téguéyé ké jaspe goula gnani, fonkrouwa agua kho
crystal.

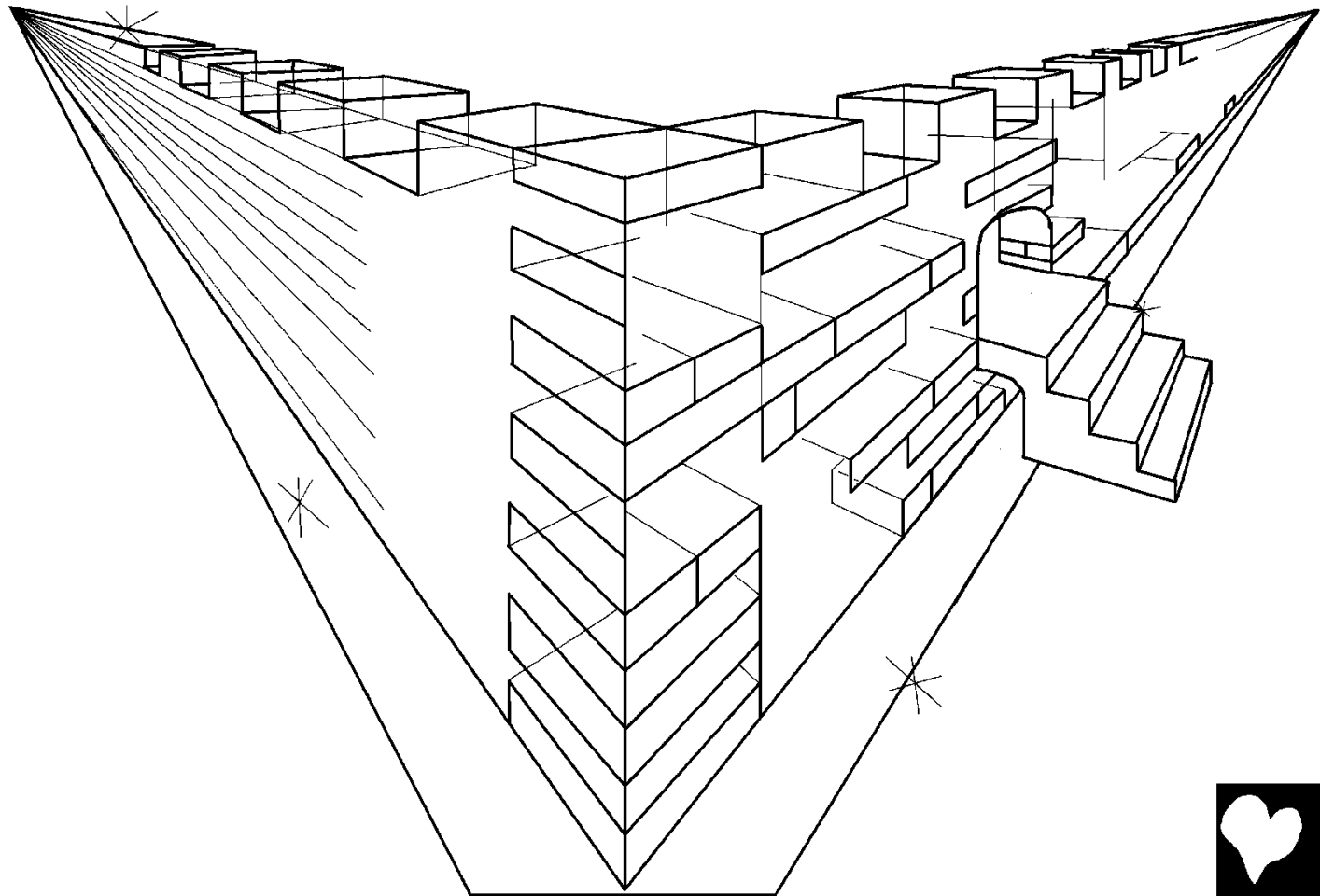

A folakhou dinkani pérles ngayé inti tékhini
abada. Ondanga fayi kébé gua doonou ... Euw!
Ardiana frampré ni fo nokho gna. Ati débéké
irdébeury ti nkangé siré, gua kho kiyé nga koumini
mokhobé. Kha
sélaké kha
irdébeury ti
kangé gna.

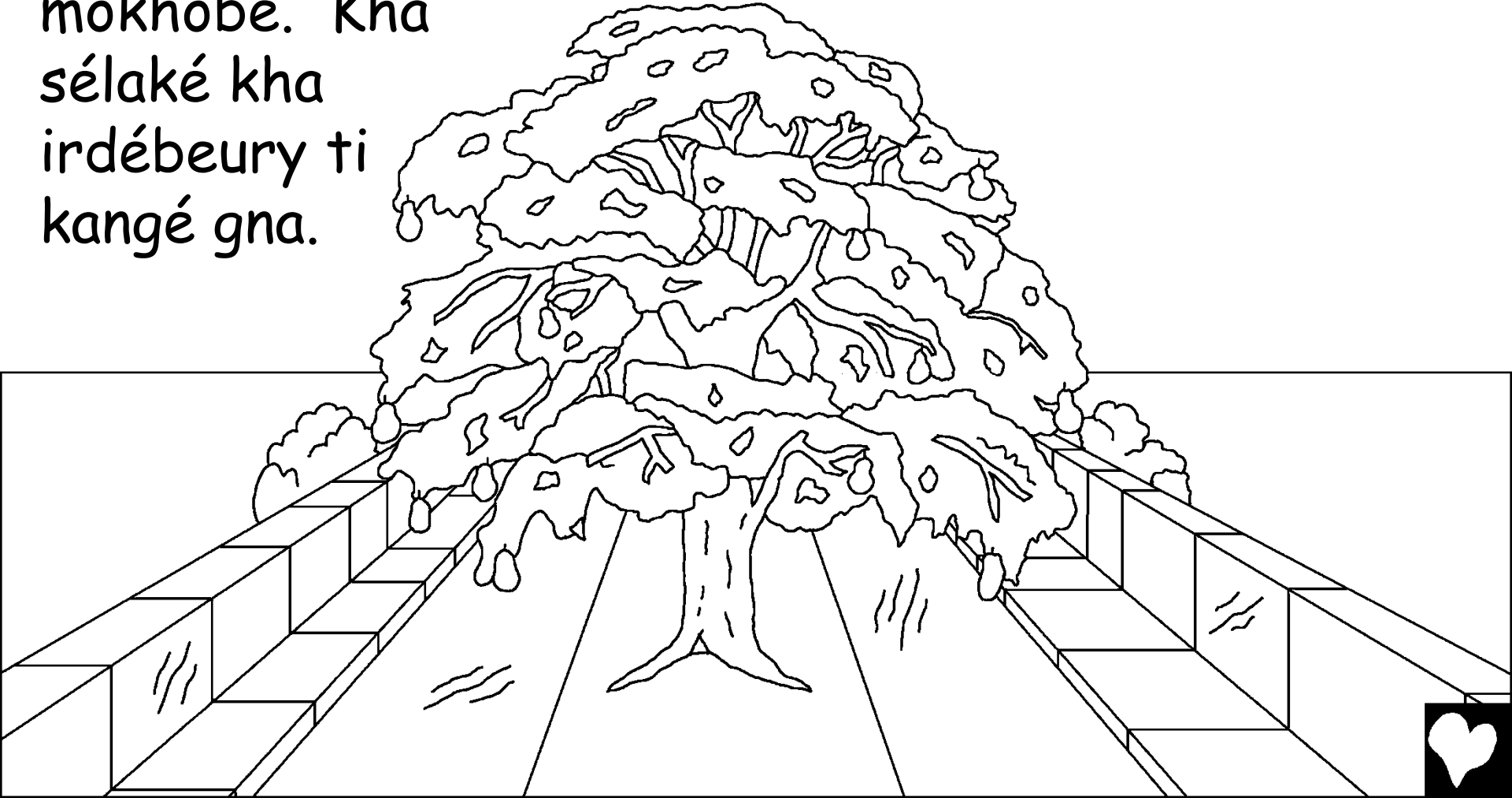

Dji frampré fo labanté ayanguili fangué aya nguir
Ala nokhou ma. Nokou tana fané ké kaara, biradi
yiité fo sire ké ni doono nga, kéyitté idi weury
ardiana gouné ya nokho. Kégnité aro yité sountou
baana. Yitéké yitéromou kamoudo fillo idoono intou
baana, khaso sou tamoudo fillo tana yirini. Ati
yitidéré ké kénni na xadama rémé ko diarra.

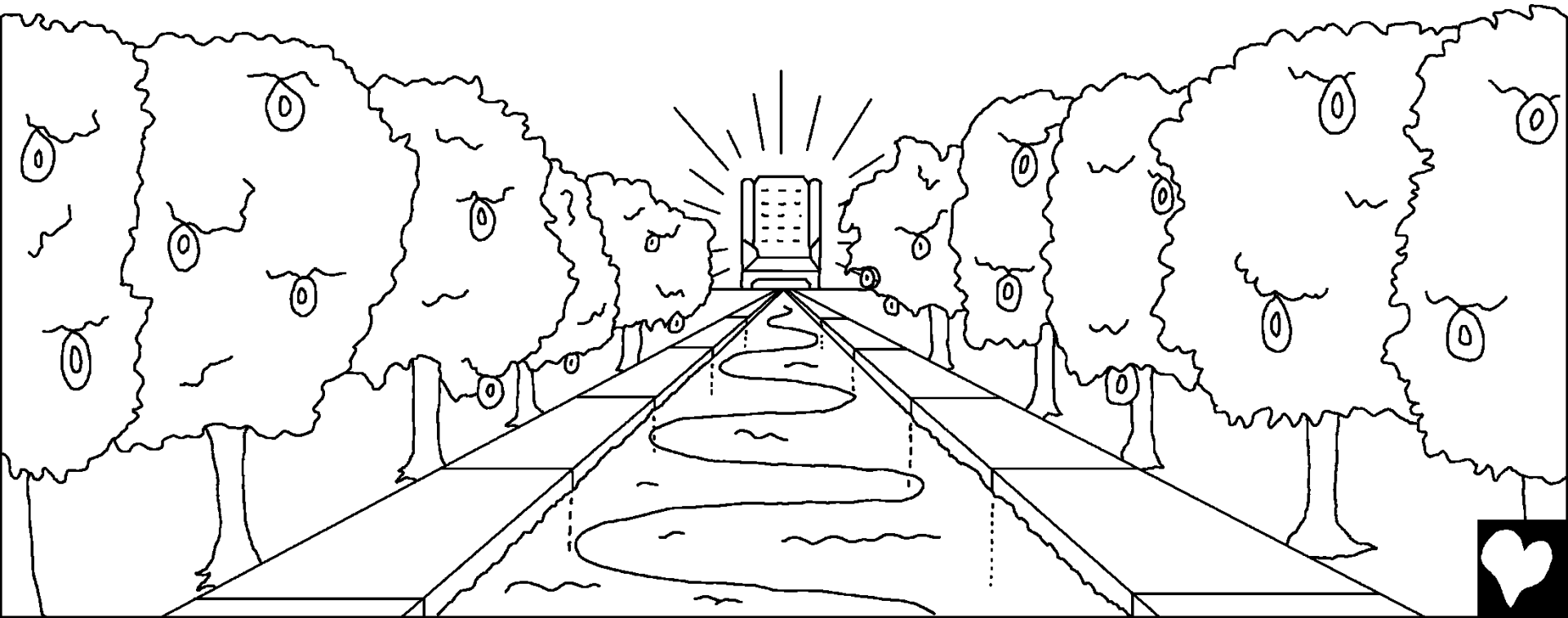

Ardiana akha diountou kiyé nga wala khasso gnai na biiré. Ala ayani fakka khéri na. Doono nga ngontou rono abada.

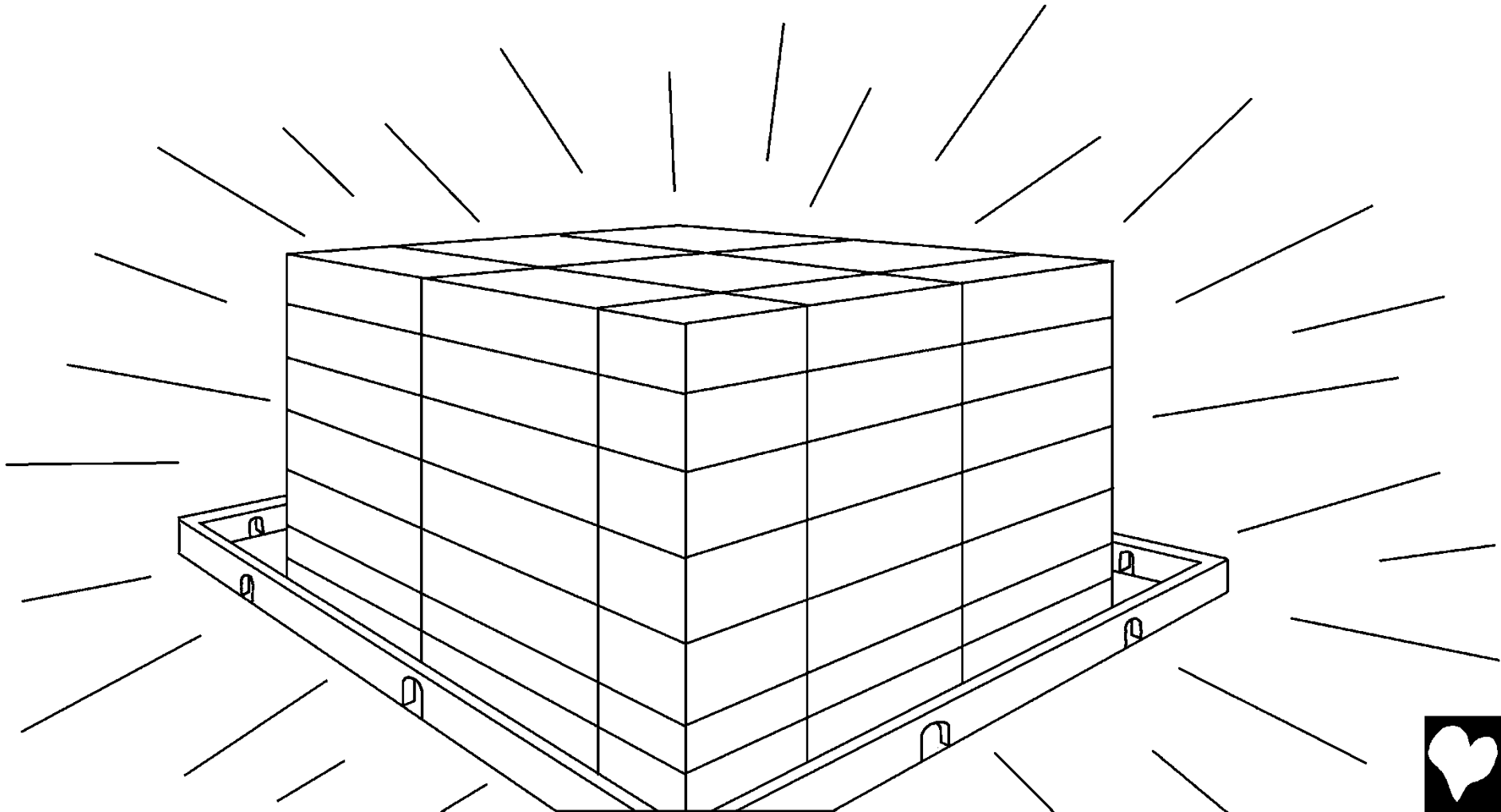

Khar nabourou bégua ardiana mokho ido koutou inti baana. Isou sourou gnani. Touroungué aro diokho ini sokké gna yiguana. Khar diéritté nkha an sokké gna yiguana kho na mokho. Ala ti "Nti diogui ndini nti fo bonondi goula dinka ké kara."



Igua fayini, irtou
nanti fobanté ardiana
nokho. Sorsou nti
séfékhané mouk.
Sorsou nti guédiana.
Fo lakhou kou
xarlomou nté,
ardiana fayana
ntéyi. Guara nté
ntéyi, sérékallana,
soukhougna,
wala sembenté.
Ardiana diounoubou
sountou doono.



Ardiana aro Ala
yakha ndjini nti
doono. Dima yoguo,
sorou kou y wounou
do douna tokhé
mbatté. Ardiana,
Ala ayi yakha ndjini
ntiou soura nga.



Nkallé nti ardiana. Ala komou iro Ala idomé abandan. Fo mamanté iti doono, wouye ntéyi, fo tokhé ntéyi. Watté ntéyi, bogoumé ntéyi, firindé ntéyi. Ardiana asouyi sowoono ido Ala.



Kébé lingue nguéni, ardiana ani gna makha manou kou ado yakhanou (aro fo khorou) koubény sékhenté nga Isa idéma ndaa na idoungué adanga ayani Ala. Aridiana kitaabe idoono atokho nguini Nabourou kitaabe douna nokho. Afaka gnani xadama rémé ntokho. Khayi tou iguiri tokho nibé safa doono? Koubénou sou sekhinté nga Isa.

An tokho ngui doono mba?

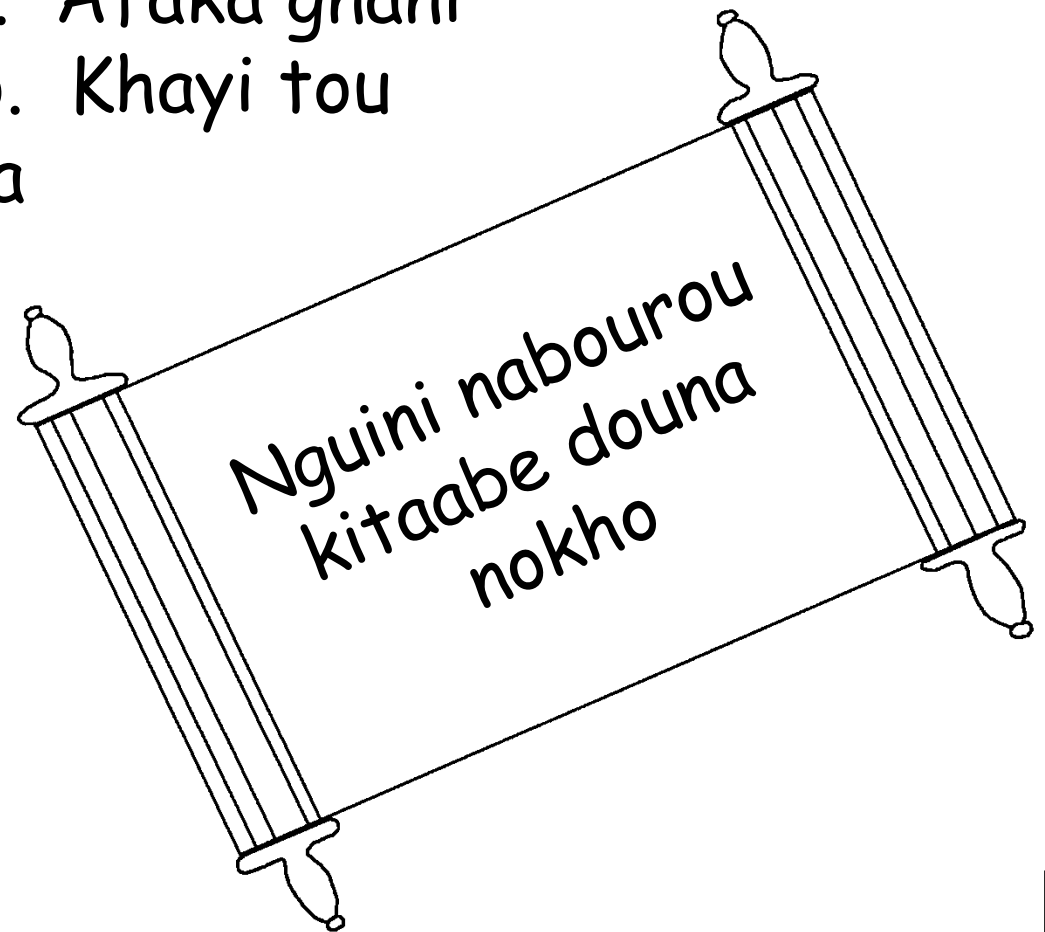

Kitaabe ké digua léguéré ti aridiana khibaarou ayani khirillé rampré. "Khakilé aro yokhou nté, 'Lii!' Ako ibé guana mougou ana ko akama nga 'Lii!' Anawara takou nguana ibé ragua ana lii. Séré bé gua moulla, awara ana douna dji ngottou agua linga danga".



Ardiana, Ala ka frampré

Guanee khibaree Ala seffe, kitaabee nokho

arworri anokhonga

John 14; 2 Corinthians 5;
Révélation 4, 21 22

"Antiofou kouga rono mokhobe anifou koura
na riteenee." Psalm 119:130



Agnemee

| 60

||||| 60



Gaani kitaabe isefenne o dangaa
Ala xeery be guiroriiti a gamoula onitou.

Ala aïtou o rifobrou igna deubeuri, y ña kinxili diounoubou.
Diounoubou nkilee kale ña, Ala adoxanou siri ke ñaani aguir
ireemembamee xayoya, annebi Isa, a karasolee ñakhama aro xala
ki o diounoubou nxama kempalee. Annebi Isa aridou naya aroo
arijaana no kho, Seeli kha sexintee ñaani annebi Isa ona ñaaña
ona ñampandou diounoubou nxama, ay debeurni! Ayirinee ay
birenee pour o danga lenki, o xada oday birenee mee nxana.

Selee xa guisee xey tee tongou ñaani, oy ke kongo Ala danga:
annebi ñimee Isa, o rissima Ala nanga aliña xadama reeme
angarini kara pur o diounoubou, lenki kotaake ampa bireene. O
daxa ñagua, khanari o douna nokho anañampa o diounoubou, onari
biree mokho siree xama, oymoula kota odana ña mee xana
kotassou. Ndeema onambotou ado ona mbiree andanga coma
alemee. Anmiina.

Ana kitaabe kewara ando Ala nan cheefe kotassou. John 3:16

