

Gidraḱo laḡit Baibel Sasapraoiç

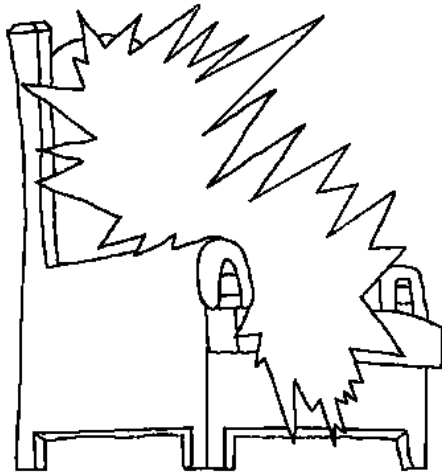

Sermare, Isorak' monj oraḱ



Olok' iç Edward Hughes
Phen kathako hudisiç Lazarus

Torjomayiç Samuel Hasda
Ataniç Sarah S.

Turuigel golpoko khon turuigelak' golpo

www.M1914.org

Bible for Children, PO Box 3, Winnipeg, MB R3C 2G1 Canada

License: Noa golpo do copy arem print daṛeaka, menkhan aḱhriin do bam aḱhriin daṛeaka.

Santali

Tinre Jisu do dhartireye tahēkana unre uni do aḱren celako serma raj reake laiaḱko tahēkana. Uni do onae metaḱkan tahēkana, "Inren Babawak' Oraḱ," Are menet tahēkana onḡe do aema jaegako menaka. Onḡe do aḡi utar tahen jaega ar monj jaegako menaka. Serma raj do dharti reak' etak' etak' oraḱko khon hō maraḡgea ar aḡi monjgea.

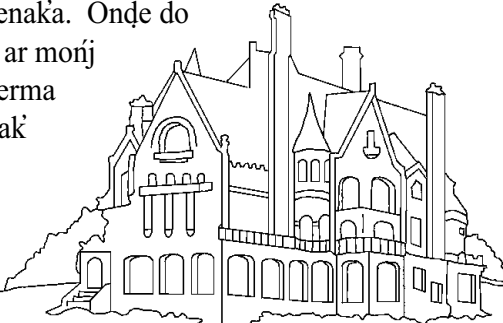

1

Jisui metaḱkoa, "In do ape laḡit jaega tear in calak' kana. Ar calaokate ape laḡit jaegaḱ saprao lekhan, in do arhōn ruar hijuka ar in thenin ataḱ idipea." Jisu do goḱko khon bereḱ ruar tayom sermateye rakapena. Ar tinre aḱren celakoko horhoyedekan tahēkana unre uni do coḱteye rakap' ocoyena, ar miḱten rimil do uniye ataḱ idikede.

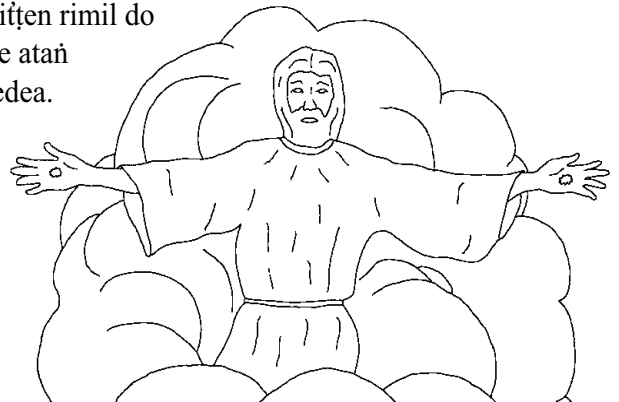

2

Tinre, Isaiko do Jisuko disayea unre Jisu do gokak' lekae ruar hijuka are idikoa. Jisui meneda, Iní do usaragen ruar hijuka, one tinre huđinakko atańok. Menkhan okoeko isaı do Jisu gujuk' lahareko goćakan onkoak' do ceť hoyoka? Baibelreye metabon kana onko do sojhe Jisu sańoteko calaka. Abo do tinre hořmore babo tahena unre Probhuh sańotebo tahena.

**PROBHU TULUC
BON
TAHENA**

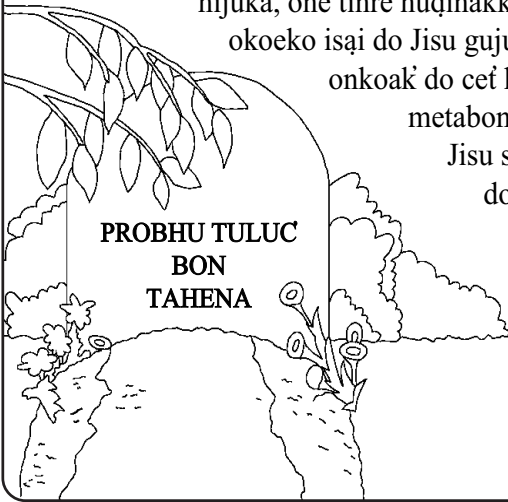

3

Johan řhen sodorok, Baibel reak' mucať utarak' puthi do, aboe lai abon kana serma raj do tinať monja mente. Ona do ađi monjgea, ar sermare Isorak' oraťte calak' hor hõ bhagegea. Isor do joto jaegarege menaea, menkhan uniak' singhańon do sermarege.

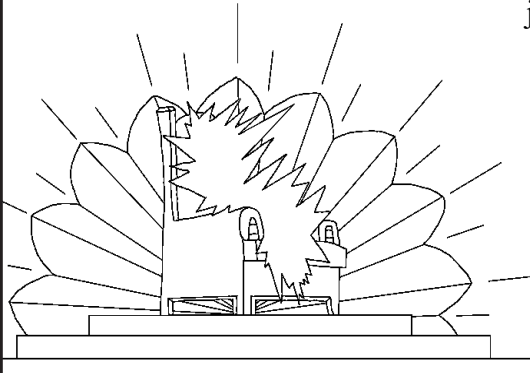

4

Sermare gođetko ar etaťko do Isorko sewawae kana. Ona iaťe Isorren sanam hořko tinreko gujuka unre onko do sermateko calaka. Onko do Isorko orhẽ sereńaea arko sarhaoea.

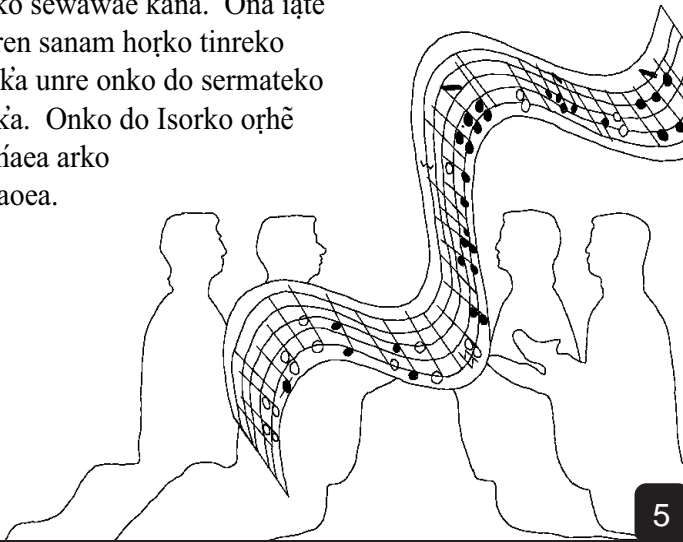

5

Nonđe oneko sereńetkan ona reak' thořa katha menaka: AM DO AMAK' MAYAMTE DHARTIREN MIMIT' BOSKO LAĐIT RAJOSTIM BENAOK AKADA AR ISORREN NAEKEM HOEAKANA. (Johan sodor. 5: 9)

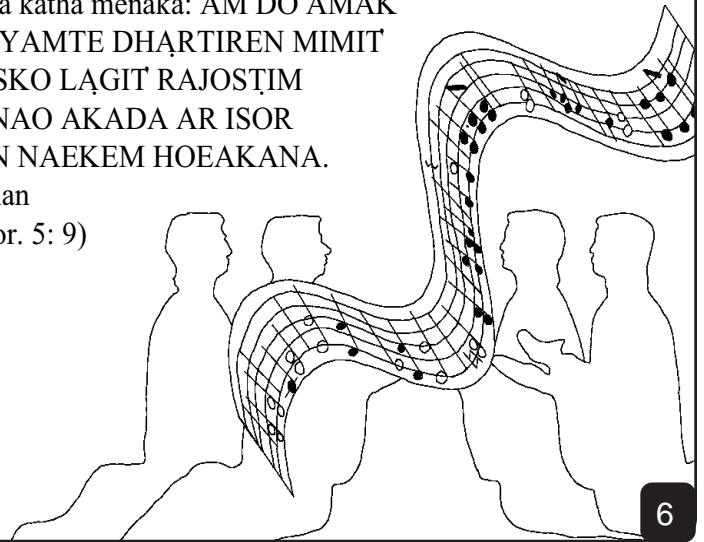

6

Baibel reak' mucať sećre serma rajre "Nawa Jerusalem" reak'e lai abon kana. Ona do ađiteť marańgea ar ona reak' bahre paćriko hõ usulgea. Ar paćri do damanak' dhirikote, ar shapa kać reak' kana. Paćri reak' rehet' do sanam lekan damanak' ar monj monj dhirikote baısařu menaka.

Ar joto duar do mimit' goťen mańikte tear akana!

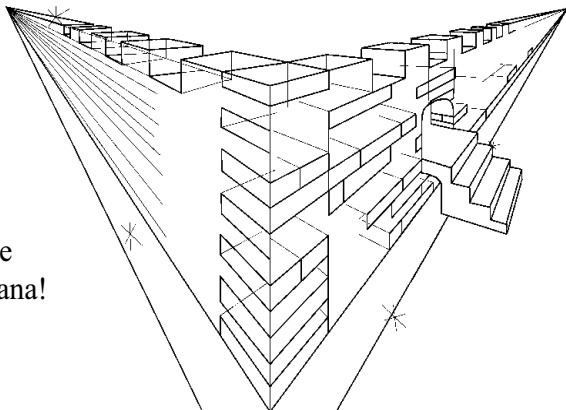

7

Onako mańik reak' duar do tishõ bań sińoka. Delabon ona beřhaete bon nel aćurma...tinať monj. Serma reak' rajostı bhitri hõ monjgea. Ar nagraha do khaťi sonate benao akana one okaťak' do sapha kać leka nelokkan. Ar ona reak' horko hõ sonate benao akana.

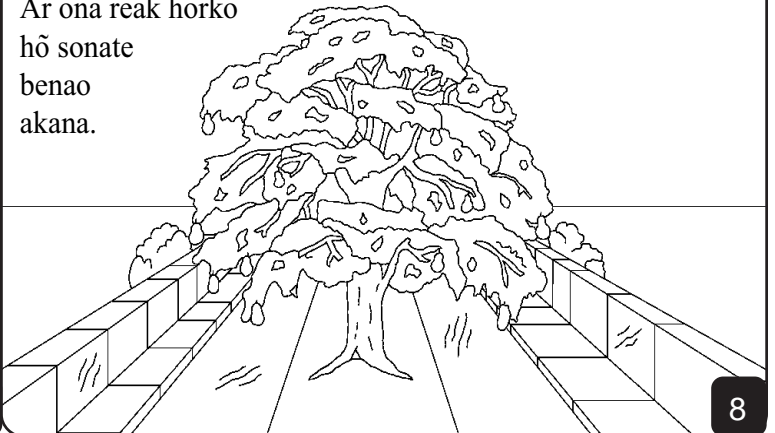

8

Ađi moñj, riřim gađa ar jiwet dakko do Isorak' siñghason khon ațu ođok hećakana. Ar ona banar seće do jion dare menaka, one okaťak' do Eden bagwanre tahēkan. Noa dare do ađi bhagegea. Ona do gelbar goťen jo jokkana ar gelbar candoge. Ar ona dare reak' sakamte do jať jaťrenko bogek' kana.

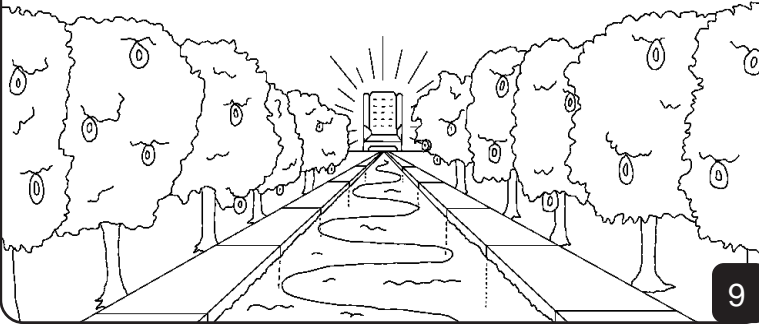

9

Serma rajre siñ cando ar ninda cando reak' marsal do bañ jařuřa. Onđe do Isor aćeťge řhonoke sodorte moñj marsale emoka. Ar onđe do tishō bañ nindaķa.

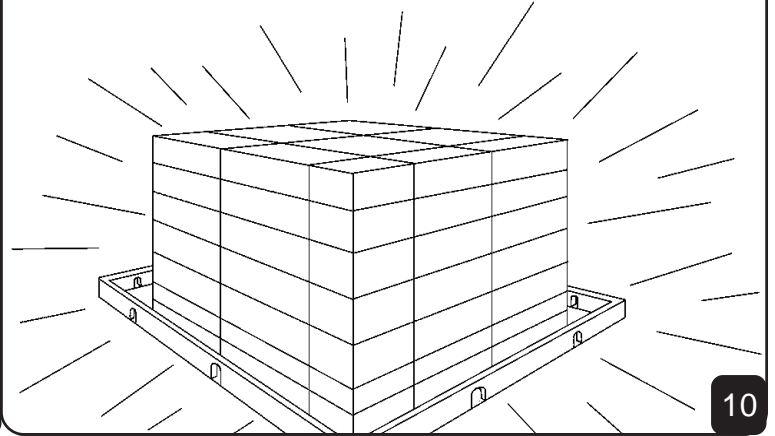

10

Unre janwarko hō sermare eťak' eťakko tahena. Onko do sanam għarićren gateko hoyoka. Tařup' ar bhiđi do miť tekin aťina. Ar dařean dhaci kul ar dañgra hō miťtekin joma. Probhui meneda, "Onko do inak' sonot burure bako ruaka ar bako josaoka."

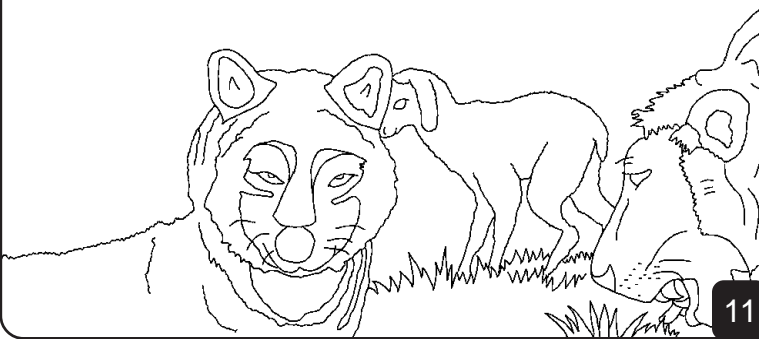

11

Ale do ařibandhikatele nelkeda arle lajeda je, serma rajre nonkanakko do banuka. Onđe do reñgeć hō banuka ar tetañ hō banuka. Onđe do jhogra jħaťi hō banuka.

Duar do tishō bañ sińoka, ente onđe do jħań kombro hō banukkoa. Ar eře rorořko hō banukkoa, khuniħhiko hō bań, onđe do hađrap hoř hō banukkoa. Ar onđe do kař hoř hō bako tahena.

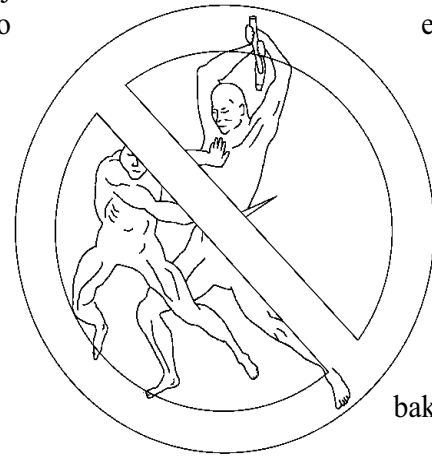

12

Sermare Isor saote okoeko taken onko do meťdak' hō bań joroktakoa. Isorren hořko do akoak' duk iaťe thořa għarić lađiťko raga. Menkhan sermare, Isor do sanamkoak' meťdake jodtakoa.



13

Sermare gujuk' do banuka. Isorren hořko do jaejug Isor tulućko tahena. Onđe do jħań duk banuka, rakjoń banuka, haso banuka. Onđe do ruā banuka, bidā banuka, onđe do topahō banuka. Sermare do sanamkoge Isor tuluć jaejug sukreko tahena.



14

Sanamak bhagegea, serma rajre koꝛako ar kuꝛiko (harakkanko – ar jotoge) okoe do Jisu Maꝛi akoren babaꝛcaoiꝛ kanae menteko paꝛiaukkan onko jotoge Probhu doe daya akoa. Sermare do miꝛten puthi menaka one oka do bheꝛa hoponak jiwet reak puthiko metakkan. Noare do hoꝛkoak puꝛa nuꝛtum menaka. Am do cefem baꝛaegea onare okoekoak nuꝛtum ol menaka mente? Tinaꝛ hoꝛ do Jisureko paꝛiaꝛ akan onko sanamkoak nuꝛtum onare ol menaka. Amak nuꝛtum onare menakgea?



15

Baibel reak ses utarak katha do hoyok kana serma reak monj utarak neota. “Sonot Jiu do bahu kuꝛiye metaekana, ‘Dela hijukme,’ Ar okoye anjometkan ‘Dela hijukme,’ Okoe tetahedekan uni do uni thene hijukma. Ar okoe nuꝛu sanayede uni do hekkate jion reak dak maꝛgnateye nu idi joꝛma.”



16

Sermare, Isorak monj oraꝛ

Baibel reak noa golpo do Isorak katha kana,

Noa do namoka

Johan 14, 2 Corinthiko 5, Johan sodor 4, 21, 22

“Amak katha reak seledok do marsale emoka.”
Serenko 119:130



Isore baꝛaegae abo do baꝛicaꝛ bon kami akada, one uni do okaꝛak kaiye metakkan. Kai reak kuꝛai do gujuk kana.

Isor do abo nonkae duꝛaꝛket bona uni do acꝛen hopon Jisui kolkedea, uni do aboak dukkoe jomkeda ar krusreye goꝛ ocoyena. Jisu doe jiwet ruꝛ akana ar sermateye calao akana! Nitok Isor do aboak kaikoe ikaꝛet tabona.

Judi amak kai khon ruꝛokem menet khan endekhan Isor metaeme: Duꝛaꝛia Isor, iniꝛ paꝛiauk kana Jisu do in laꝛite goꝛlena ar nitok do arhoe jiwet beret akana. Onate dayakate inak jionre hijukme ar inak kaiko ika kaꝛinme, ina khan in do nawa jionin nama, ar am tuluc jaejug haꝛic in tahena. Goꝛowaꝛime amren hopon lekate taken laꝛit. Amen Johan 3:16

Baibel paꝛhaome ar Isor saote din hilok galmaꝛaome!