

Mbia be Bible

Ta abaya a sa

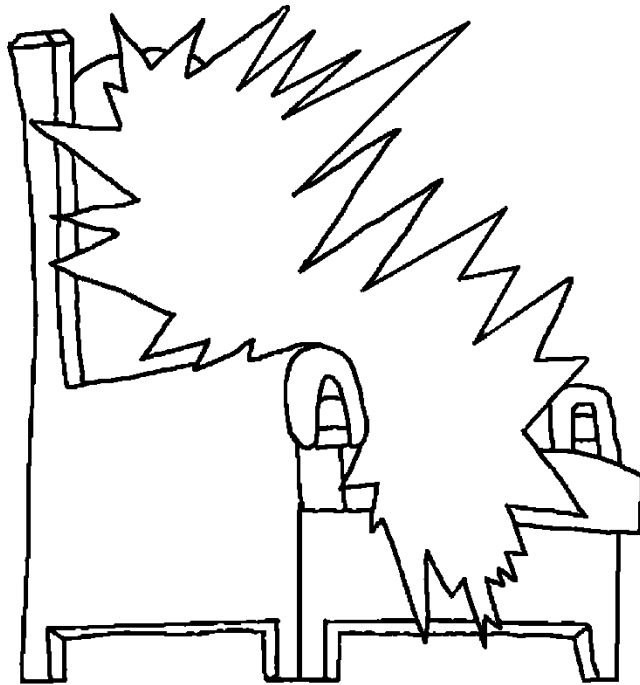

**Esonso, Ebore
be kade lala**



E sibεpo ela: Edward Hughes
Ewɔrɔpo ela: Lazarus; Alastair P.
Esɔpo ela: Sarah S.
Ekilgipo ela: Dramani Dari
Ewɔrɔpo ela: Bible for Children
www.M1914.org

BFC
PO Box 3
Winnipeg, MB R3C 2G1
Canada

©2021 Bible for Children, Inc.

Fo kɔ ekpa nε fo tiη pirint kesherkpaη na, nε fo ti ya maη fa kumo bre.



Yesu ka daa wɔ durnya to e daŋ kaŋε bumo esonso be aseŋ. E tere kumo mo tuto be lanto, n kaŋε faŋε alan gboŋ lɛla nawule e wɔ ndoŋ. Ndoŋ be alan waɛ achɔ durnya to be lan kike.

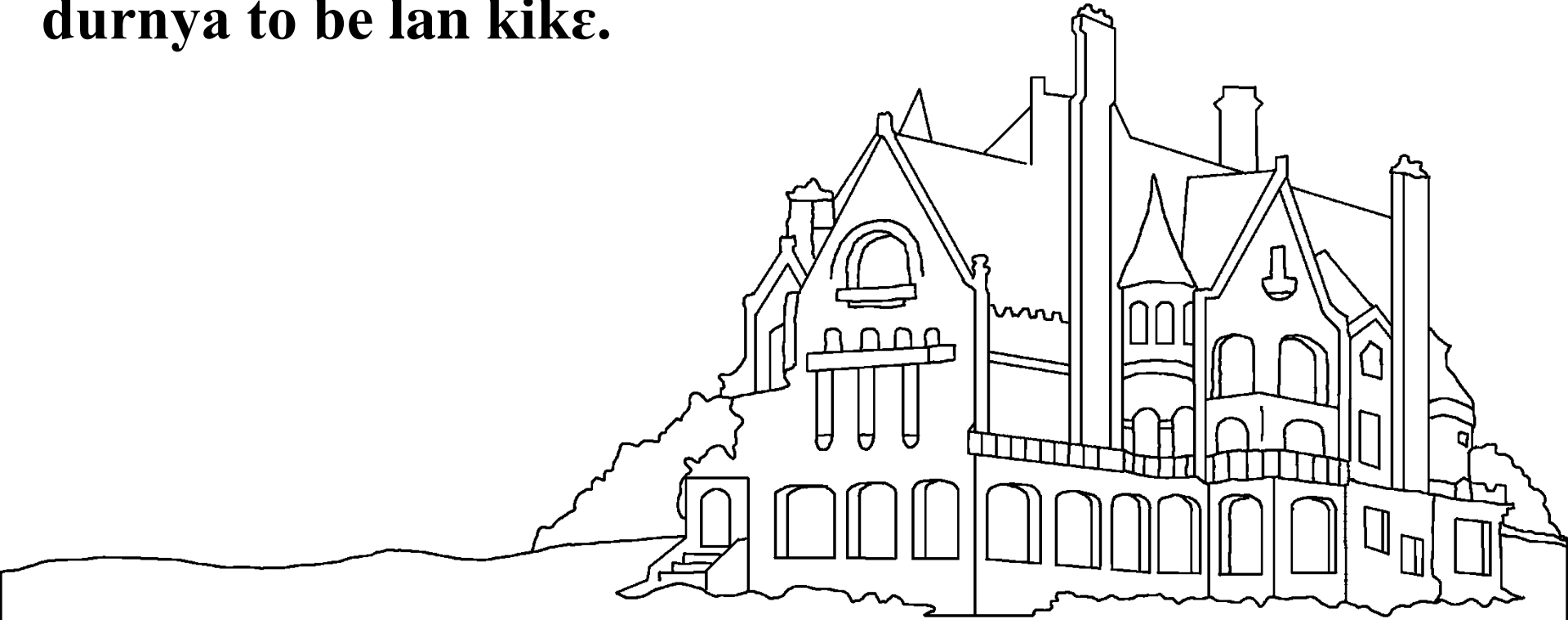

Yesu dan kaɗe, “mee yo ne n ya lone kabon n yili menye. Ne n kan ya lone kabon na n luwe, meen beta m ba so menye n wato mo to.” Yesu dan yo esonso saɗe e daa tiji luwu to na. Mo kamanto ka yili a keni, ne ewurbore ta mo n dii esonso, ne ewulpo buu mo so ne bu man nan wu mo.

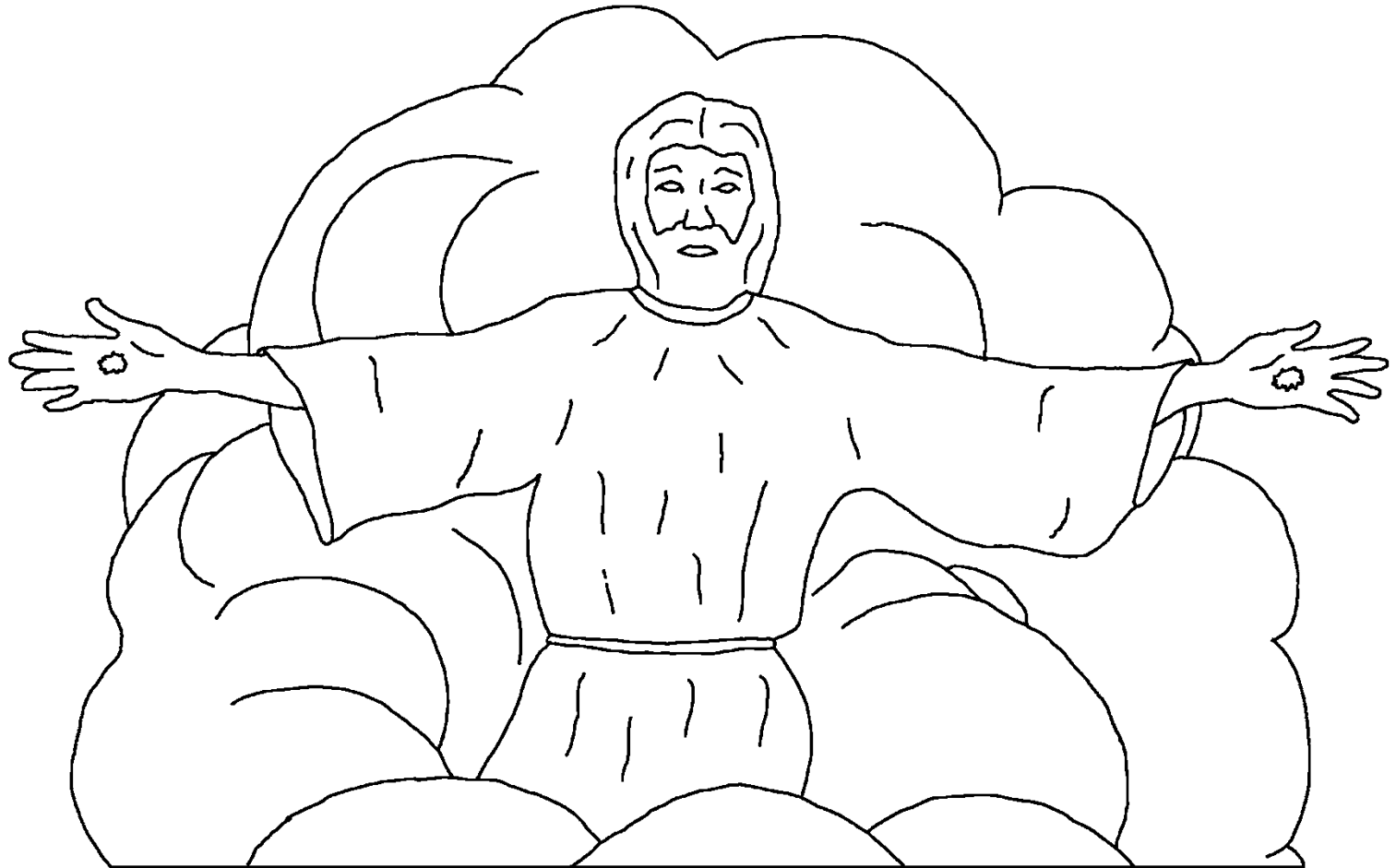

**Baŋ yili loŋ be saŋε, nε kristo ebi bee nyiŋi Yesu be
kanase fanε e beenε laŋε m ba sɔ bumo. Yesu yε e beenε ba
purgi bumo. Nε nuso nε baasa nε bu wu
pɔε nε e ba na ai? Bible ŋini fanε bu
yɔ Yesu kuto. Ku wu ŋini fanε
fo wɔ Ebɔrε kuto.**

**Nε awɔ Ebɔrε
kuto**



**Kelara n ɲini, Bible be lalaluwe be buku, kaɲe anye
kanane eboso du. Mamachi sheɲ ne e la, esonso ndoɲ
la ewurbore be kowu nna, Ebore wo mplekama, ama mo
lembu wo esonso.**

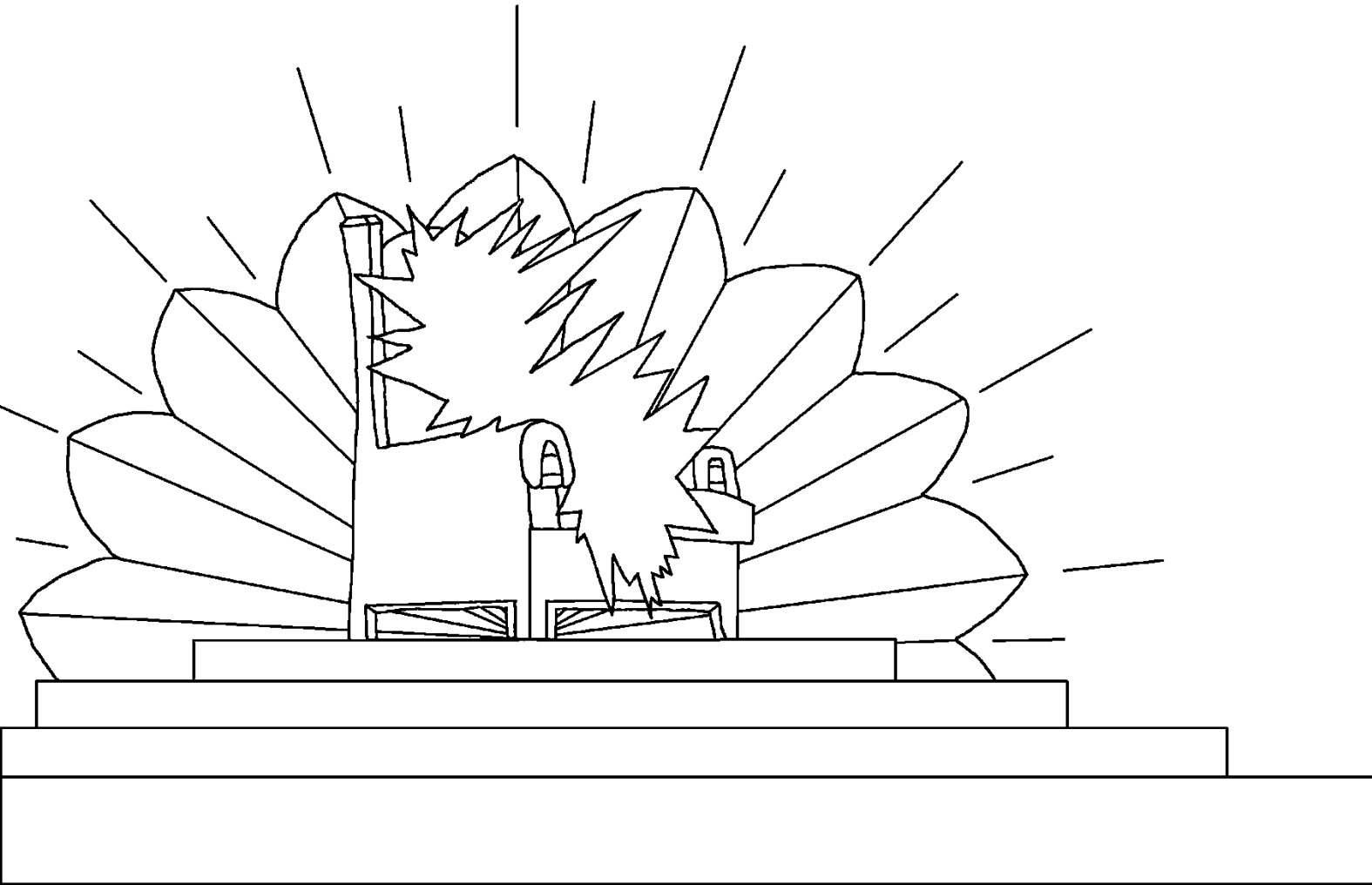

Ebore be abo ne kusone ku wo esonso bee shun Ebore na. Lon ne baasa ne bu wu kike bee shun Ebore.

Baa bon nshela na a sa Ebore.

Mmalga ko ashi nshela na be kukonwule nde: Anye puchi fo so nkpal fo ka ta fobe nkpan ashi ngbar kike

to n lara anye n sa Ebore.

N nan ta anye kii baasa ne baa ji Ebore be ashen.

(Rev. 5:9)

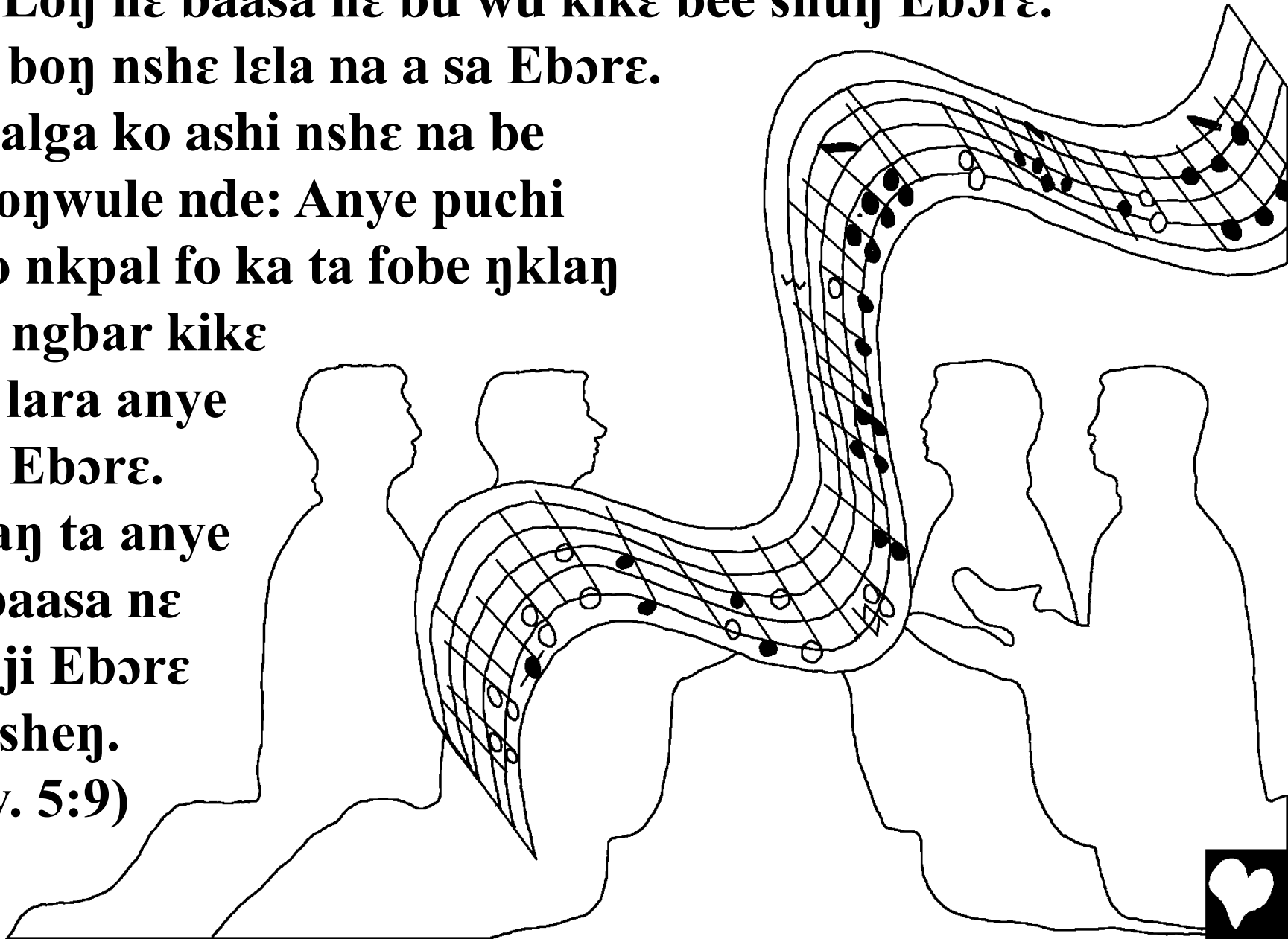

Bible be lalaluwe ɲini fanɛ esonso ela “Jerusalem pupɔr na”. Ku shi ga, nɛ egbel tentenɲ kulti kumo. Egbel na la kejembu na, nɛ ku du fanɛ shuwa. Ajembu lɛla e buu egbel na kike anyikpɛ pileu pileu. Kade na be mbuna kike daa la a fuful na!

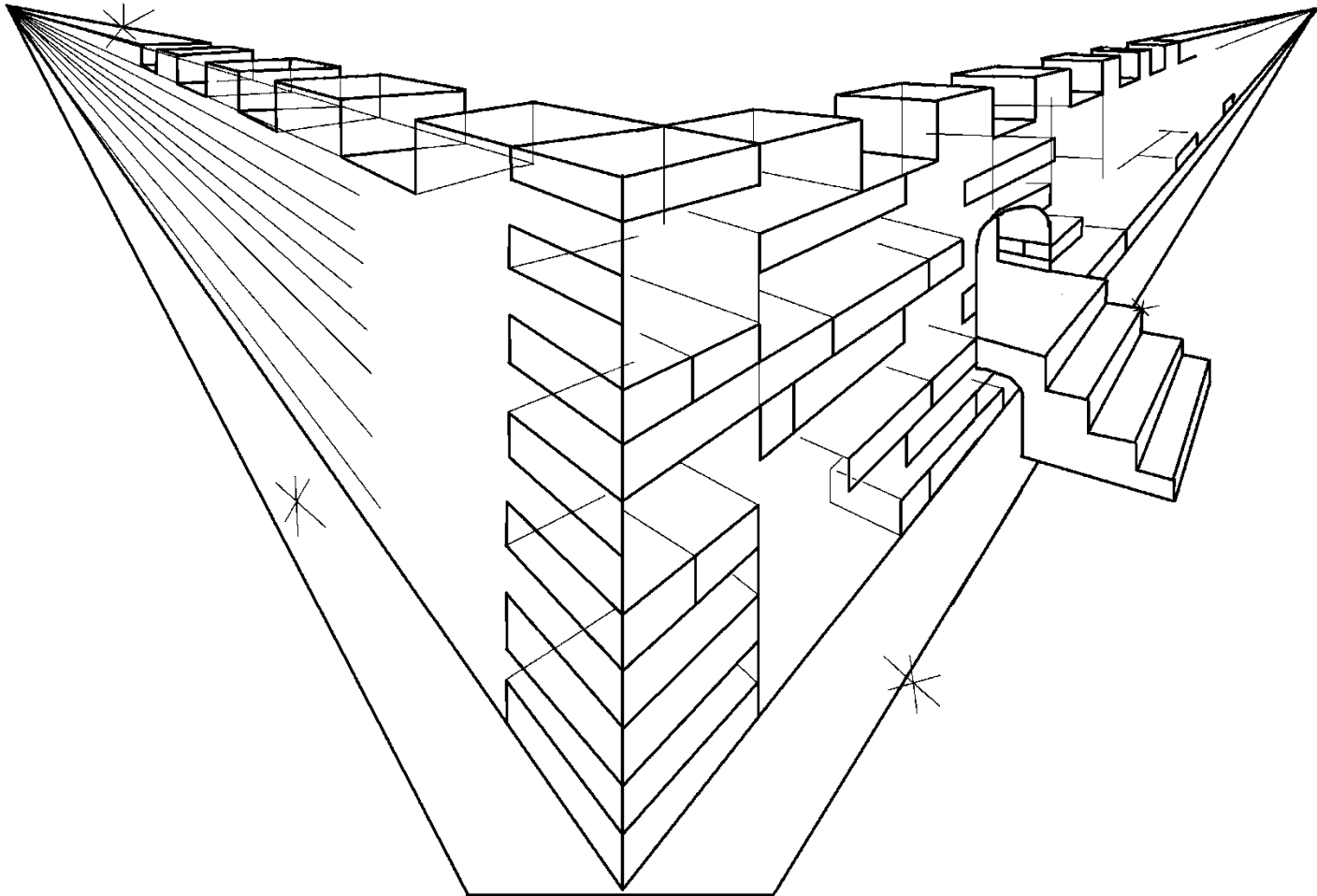

**Loŋ be ndulwi be mbuna na daa maa tii. Shinne anye e
lur n ya keni kumo be epunto ... kuo! Eboreso be epunto
wale ga. Ku du fane shuwa ne bu ta m por kumo ne ku
fulto fane aglasi. Ku duli fane shuwa ne but a lone ekpa
na gba.**

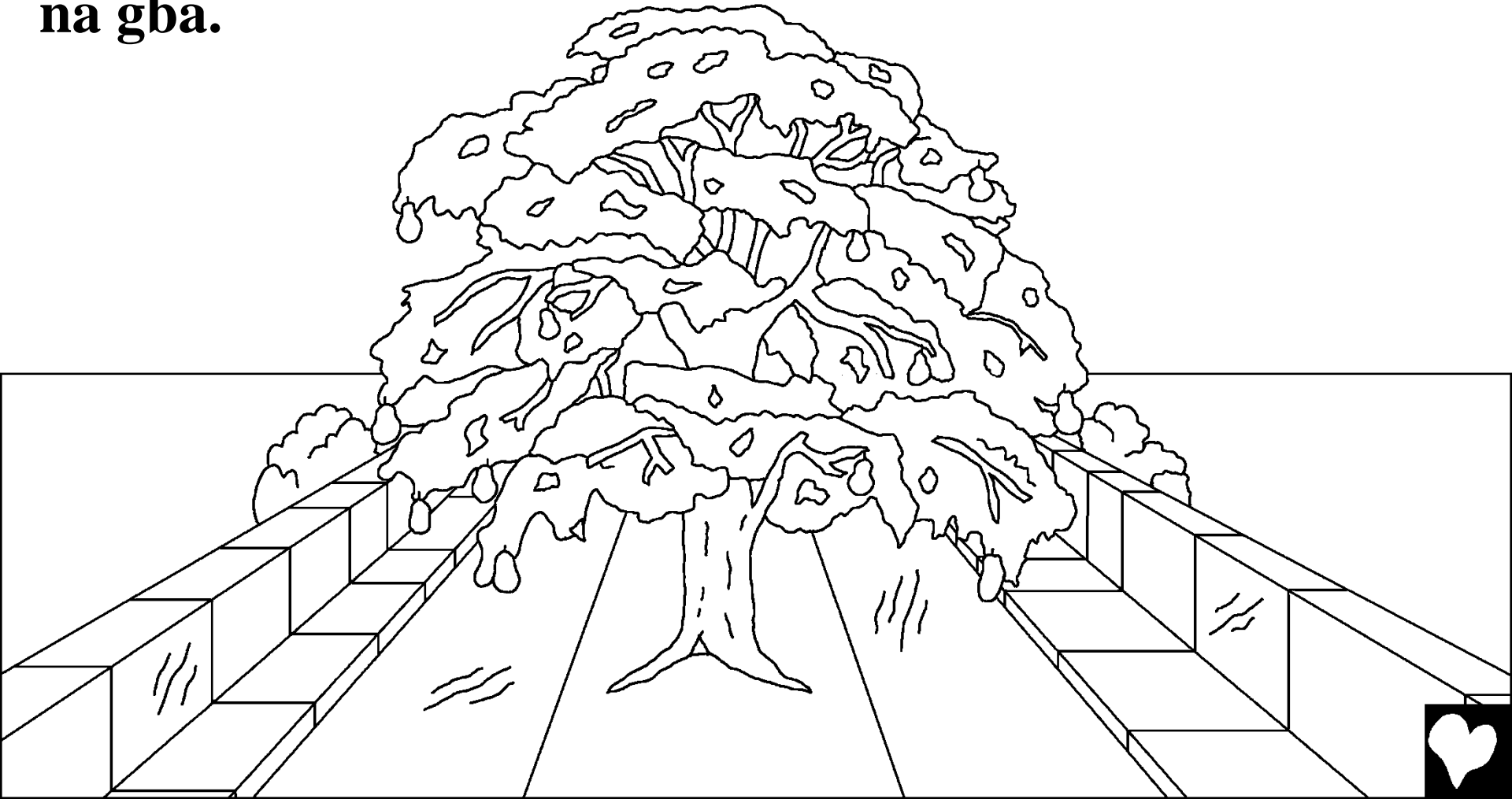

**Nkpa be lor be nchu lɛla ko e daa shile la be kabonɔ.
Lor na be mba anyɔ daa kɔ nkpa be kadibi nɛ ku daa wɔ
Eden be gadin na to. La be kadibi ere daa la kabɔrɛ nya
be kadibi na. Ku daa kɔ asorso yiri yiri beenɔ wɔrɔ kudu
anyɔ kufol kikɛ to. Nɛ amobe afantaɔ la asɔnɔ anye kɔ
achɛ durnya.**

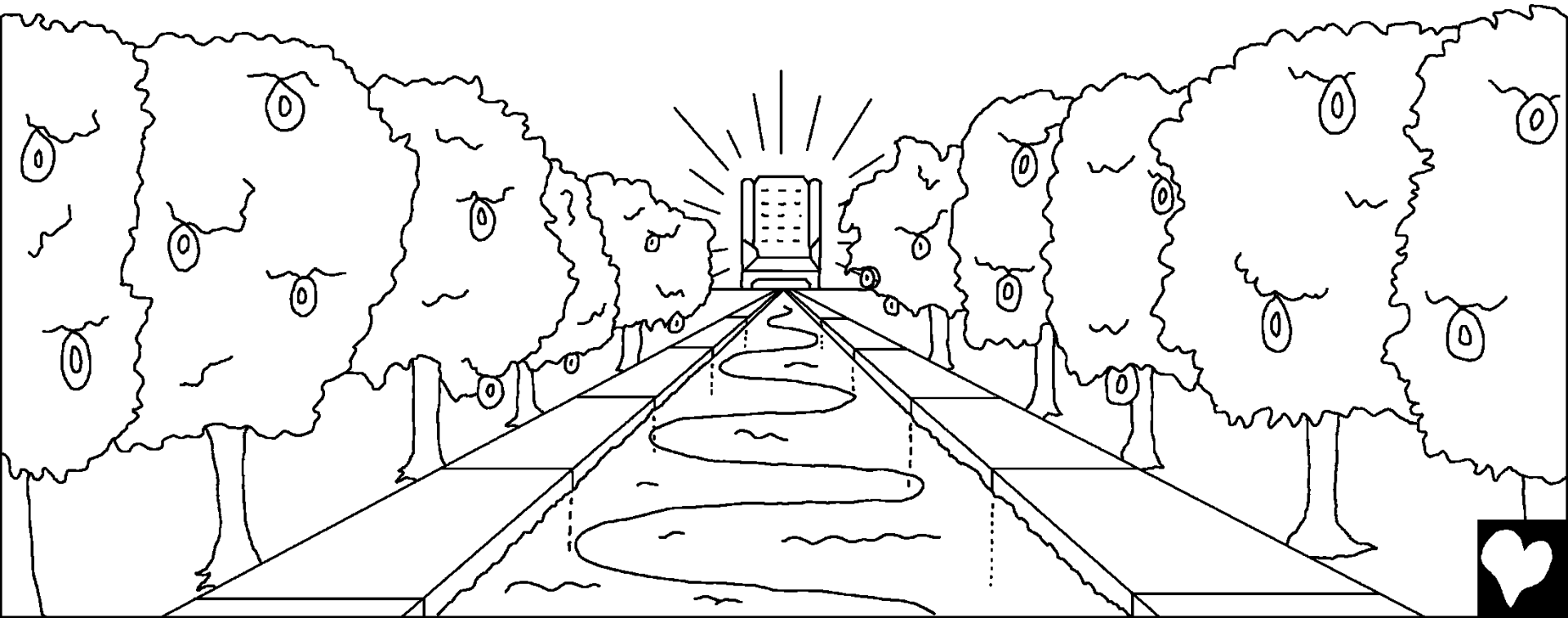

**Ebọrẹso maa shaa epeni nẹ kufol pọe nẹ ku nya ede.
Ebọrẹ be yiko e daṅ sa kumo ede. Kanye maṅ wọ ndoṅ.**

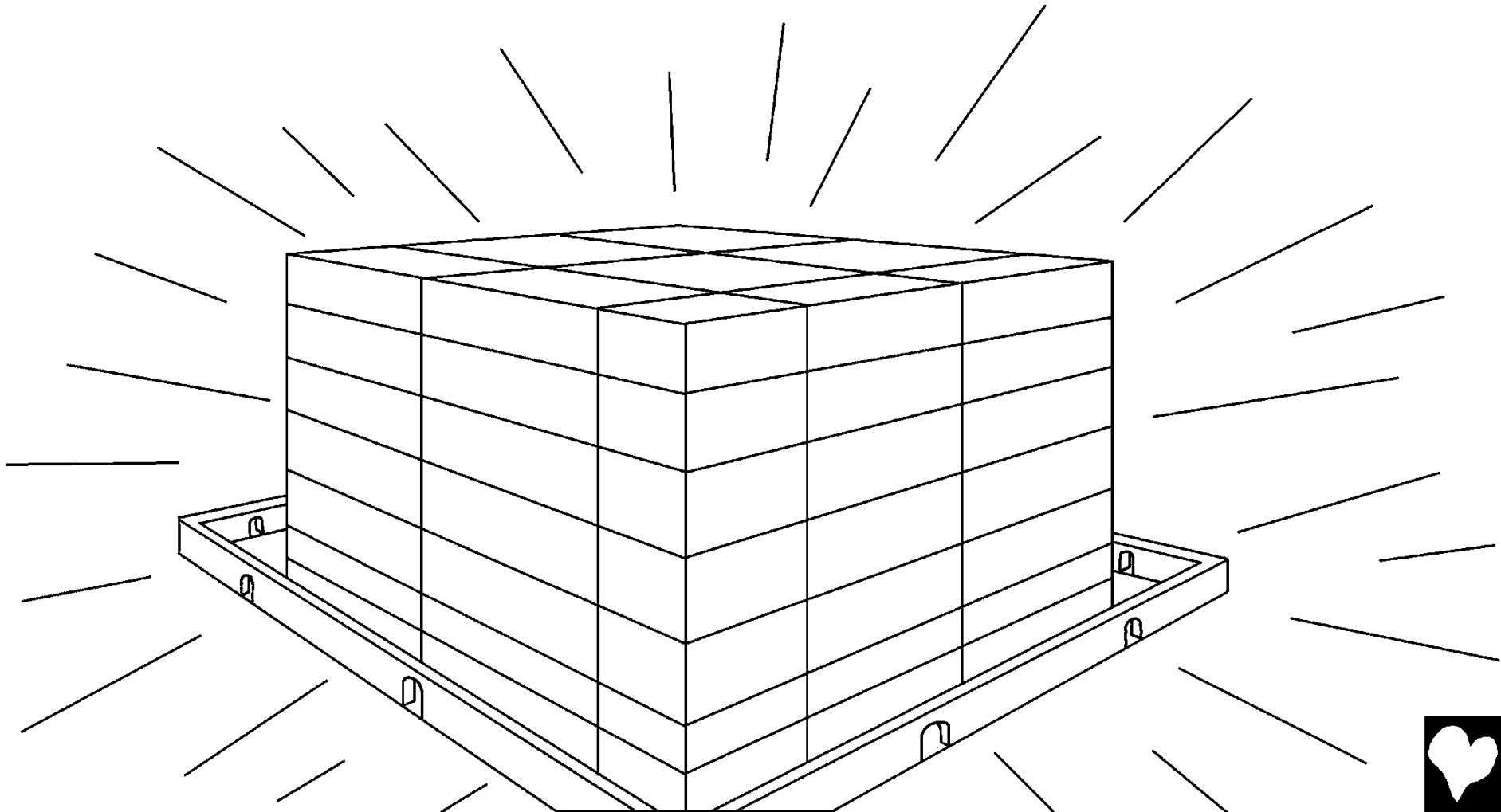

Asɔ́bɔ́aya nɛ a wɔ́ ebɔ́rɛso daɲ kɔ́r abarto. Amo kike daa nya kebala amoalɛ daa shaa baasa ga. Akuntuɲ nɛ mbɔ́lpo daa wieto nna a ji afitiri. Abuluɲ gba daa ji abolite fanɛ anaa fɛlpo. Nɛ Ebɔ́rɛ kaɲɛ, “A maɲ daga ku tɔ́rɔ́ abar mobe abee lɛla ere kike to.”



Anye ka keni nkulti, anye wu fanε aso ko foe lon be kaboη na. Agbo be mmalga daa maη wo ndoη. Kolu nko npketo gba daa maη wo ndoη. A safi gba daa maη wo ekuloη na so.

Bu fiεpo, baasa

**nε baa mo
baasa, nshe**

bompo nko

kumu to

leη wura

ana gba

daa maη

wo ndoη.

Kulubi gba

daa maη wo ndoη.

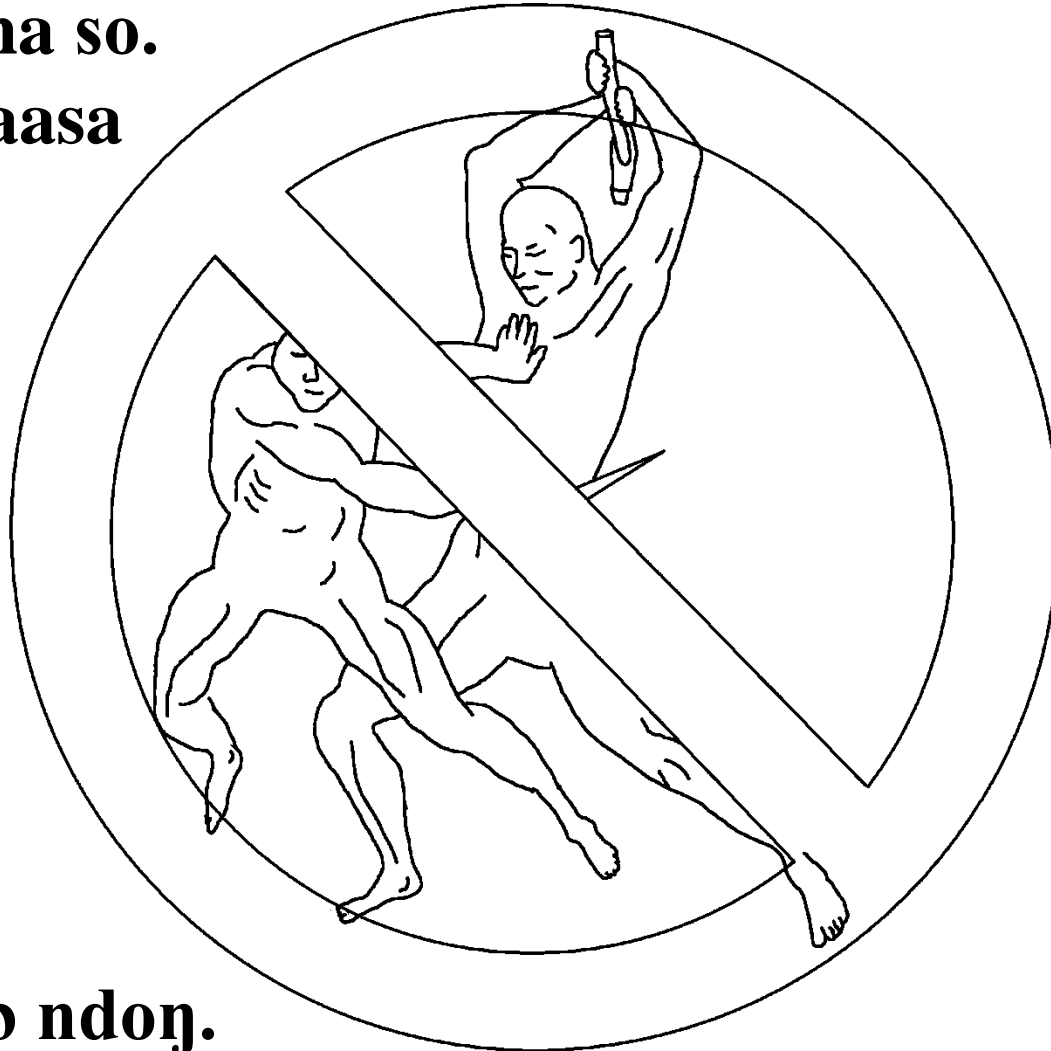

**Nε fo baa wɔ Ebɔrε kuto
kushu maη wɔ ndoη.
Saηε ko, Ebɔrε be baasa
bee shu nkpal kuwur nε
ku wɔ durnya to. Nε fo
yɔ ebɔrεso, Ebɔrε beenη
kpra fobe anushi chubi.**



**Luwu maṅ wɔ ebɔresɔ. Ebɔrɛ nɛ baasa e naṅ baa wɔ
jimanɛ kike. Awurfon, kushu, nɛ ebasa maṅ wɔ ndon.
Kulɔ nɛ nli gba maṅ wɔ ndon. Ekama be kagbene been
baṅ wushi mo na hali
m ba ana yɔ.**



**Amo ku danɛso e la fanɛ mbianyembi
nɛ bechesobi nɛ bu sɔ Yesu n ji fanɛ
bumobe e sɔpo n kaŋ bɛ mobe ekpaso
beenɔ nya kayewushi. Ebɔrɛso kawol
ko wɔ ndoŋ nɛ baa tere kumo nkpa be
kawol. Baasa be atere nwule a wɔ
ndoŋ. Fo nyi baasa nɛ bumo be
aterere wɔ ndoŋ aa?
Ekama nɛ e sɔ Yesu
n ji. Fobe kere wɔ
ndoŋ aa?**



**Bible be lalaluwe be abaya ta laɲe esonso la mamachi be
keter na. “Nε Ebɔrε be kuyɔyul kaɲε, ‘ba!’ Shinne esa
kike nε e nu abaya ere e kaɲε ‘ba!’ Shinne echukoɲ
wura e ba. Nε ekama nε ku par mo shinne e nuu
nkpa be nchu jaga.”**

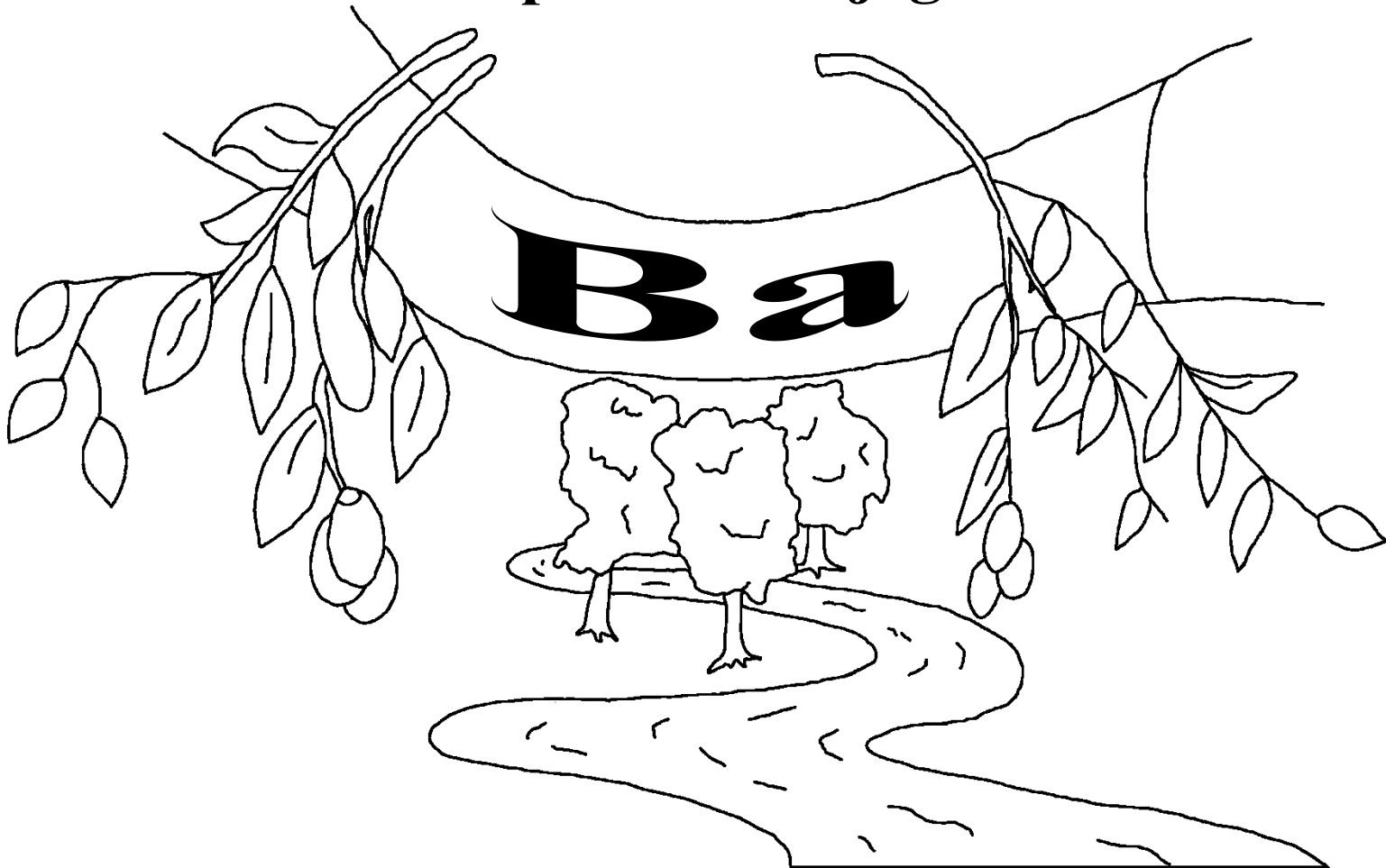

Esonso, Ebore be kade lala

Kesherkpan ko ashi Ebore be kamalga, Bible na,

feen wu kumo ashi

John 14;

2 Corinthians 5;

Revelation 4, 21, 22

“Farako na be mmalgaba bee sa kinishi buwi.”

Psalm 119:130



Lalaluwe na

60

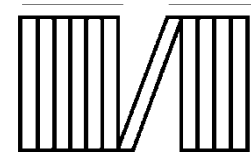

60



**Bible kaŋe anye mamachi be Ebore be
ashen ne a too anye a shaa fane anye pin mo.**

**Ebore nyi anye ka shun ashun, ne e bee tere alubi. Alubi be
kakoka e la luwu, ama Ebore bee shaa fo ga amuso ne e bra anye
mo nawule be kebia, yesu, ne e ba wu cross so n ji awurfon a kpra
anye be alubi. Ne Yeso tini luwu to m beta m ba Ebore kuto. Ne fo
so Yesu n ji n kaŋe e ta fobe alubi m pan fo. E been ta m pan fo.
E been ba china fo to naniere, ne fo ne mo e china m baa naa yo.**

**Ne fo so n ji fane ku la kashinten na kaŋe Ebore la:
N Nyempe Yesu, n so n ji fane fo e la Ebore m ba kii enyen m
ba wu n so ma be alubi, ne fo nan nya nkpa pupor naniere. Jande
ba lori ma to n ta mabe alubi m pan ma, ne n tin nya nkpa pupor
ne kachako meen baa wo kuto m baa naa yo. Che ma to ne m
baa nu fobe kamalga a woto fane fo kebia. Ami.**

Kran Bible na ne fo ne Ebore e baa malga kache kama!

John 3:16

